

A+R

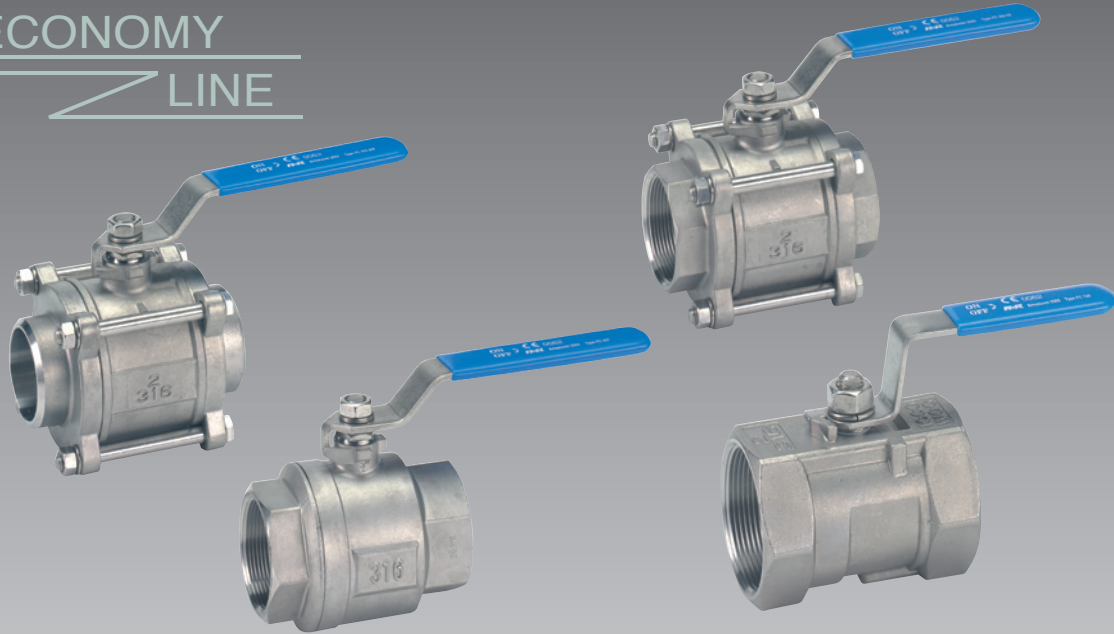

ECONOMY
LINE



**Kugelhähne mit Gewindeanschluß
und Anschweißenden**
Typ PC 102 / 207 / 302 (DIN 2999)
Typ PC 201 / 301 (NPT)

-Universal Ausführung-
R $\frac{1}{4}$ " - R4", DN 10 bis DN 100, PN 40 bis PN 63

Werkstoffe:

Gehäuse	1.4408
Dichtungen	PTFE
Kugel	1.4408

DIN EN ISO 9001:2000 - TÜV CERT -
DGRL 97/23/EG



Einsatzbereiche:
Neutrale Gase und Flüssigkeiten,
Mineralölprodukte, Laugen,
korrosive Flüssigkeiten und Gase.

Temperatur: -10 °C bis +180 °C.

**ball valves with screwed ends
and butt weld ends**
Type PC 102 / 207 / 302 (DIN 2999)
Type PC 201 / 301 (NPT)

-universal version-
R $\frac{1}{4}$ " - R4", DN 10 up to DN 100, PN 40 up to 63

materials:

body	CF8M
seats	PTFE
ball	CF8M

DIN EN ISO 9001:2000 - TÜV CERT -
PED 97/23/EC



Application:
Water, oil, gas, solution, solvent.

Temperature: -10 °C to +180 °C.

A+R

KUGELHÄHNE BALL VALVES

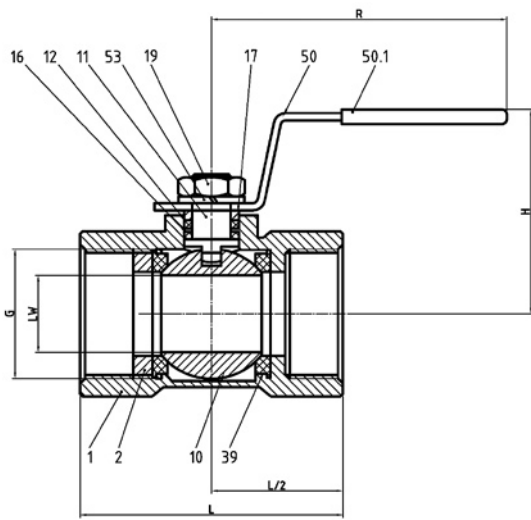

Typ PC - 102 (DIN 2999)

G	DN	LW	H	L	R	Gewicht/weight (kg)
1/4"	8	7,0	30	39,5	72	0,07
3/8"	10	7,0	32	44,0	82	0,10
1/2"	15	9,2	48	57,0	85	0,18
3/4"	20	12,5	50	59,5	85	0,27
1"	25	15,0	55	70,0	100	0,43
1 1/4"	32	20,0	60	78,4	100	0,63
1 1/2"	40	25	68	82,8	128	0,80
2"	50	32,0	75	100	128	1,42

53	Unterlegscheibe	washer	1.4301	SUS304
50.1	Handhebelüberzug	plastic cover	PVC	PVC
50	Handhebel	handle	1.4301	SUS304
39	Kugeldichtring	ball seat	PTFE	PTFE
19	Mutter	nut	1.4301	SUS304
17	Druckring	gland	1.4301	SUS304
16	Gleitring	friction ring	PTFE	PTFE
12	Stopfbuchse	packing	PTFE	PTFE
11	Schaltwelle	stem	1.4401	SUS316
10	Kugel	ball	1.4408	CF8M
2	Einschraubstück	insert	1.4408	CF8M
1	Gehäuse	body	1.4408	CF8M
Pos. item	Benennung	denomination	Werkstoff	material

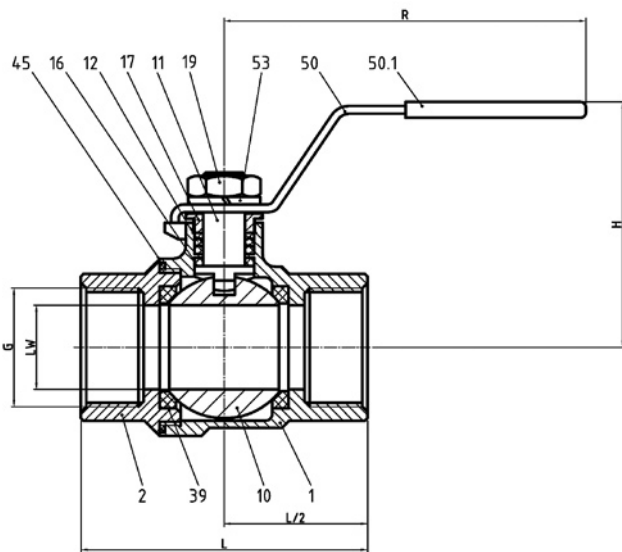

Typ PC - 207 (DIN 2999) Typ PC - 201 (NPT)

G	DN	LW	H	L	R	Gewicht/weight (kg)
1/4"	8	11,5	40	50	85	0,20
3/8"	10	12,7	40	50	85	0,20
1/2"	15	15,0	45	58	85	0,25
3/4"	20	20,0	48	64	100	0,33
1"	25	25,4	59	74	100	0,50
1 1/4"	32	32,0	64	85	135	0,85
1 1/2"	40	38,0	78	97	152	1,27
2"	50	50,8	86	115	152	2,00
2 1/2"	65	65,0	106	140	250	5,68
3"	80	70,0	113	155	250	8,80

53	Federring	spring washer	1.4301	SUS304
50.1	Handhebelüberzug	plastic cover	PVC	PVC
50	Handhebel	handle	1.4301	SUS304
45	Gehäusedichtung	body seal	PTFE	PTFE
39	Kugeldichtring	ball seat	PTFE+25%Gl.	PTFE+25%Gl.
19	Mutter	nut	1.4301	SUS304
17	Stopfbuchsverschraubung	gland screw	1.4301	SUS304
16	Gleitring	friction ring	PTFE	PTFE
12	Stopfbuchse	packing	PTFE	PTFE
11	Schaltwelle	stem	1.4401	SUS316
10	Kugel	ball	1.4408	CF8M
2	Teilgehäuse	body adapter	1.4408	CF8M
1	Gehäuse	body	1.4408	CF8M
Pos. item	Benennung	denomination	Werkstoff	material

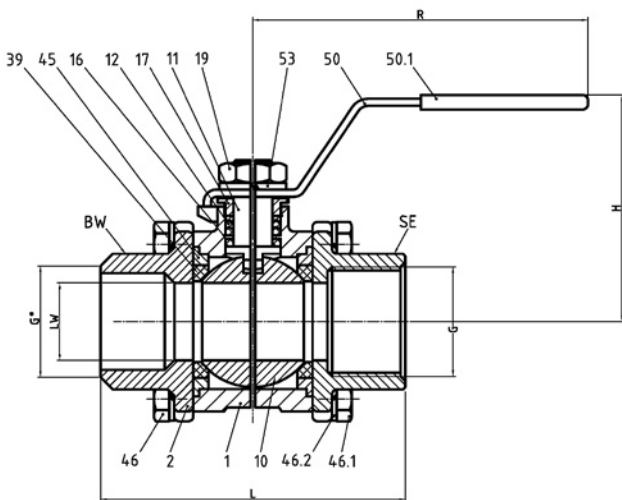

Typ PC - 302 - SE (DIN 2999) Typ PC - 302 - BW Typ PC - 301 - SE (NPT) Anschweißenden/butt weld ends

G	G*	DN	LW	H	L	R	Gewicht/weight (kg)
1/4"	14	8	11,6	44	61	100	0,30
3/8"	14	10	13,0	44	61	100	0,38
1/2"	18	15	15,0	46	70	100	0,56
3/4"	23	20	20,0	53	80	124	0,86
1"	29	25	25,0	57	90	124	1,04
1 1/4"	36	32	32,0	80	110	154	1,42
1 1/2"	44	40	38,1	88	120	190	2,42
2"	54	50	50,0	94	140	190	3,80
2 1/2"	74	65	65,0	130	165	235	7,50
3"	86	80	80,0	140	188	235	9,95
4"	108	100	100,0	165	232	263	20,00

53	Federring	spring washer	1.4301	SUS304
50.1	Handhebelüberzug	plastic cover	PVC	PVC
50	Handhebel	handle	1.4301	SUS304
46.2	Federring	spring washer	1.4301	SUS304
46.1	Mutter	nut	1.4301	SUS304
46	Bolzen	bolt	1.4301	SUS304
45	Dichtung	seal	PTFE	PTFE
39	Kugeldichtring	ball seat	PTFE+25%Gl.	PTFE+25%Gl.
19	Mutter	nut	1.4301	SUS304
17	Stopfbuchsverschraubung	gland screw	1.4301	SUS304
16	Gleitring	friction ring	PTFE	PTFE
12	Stopfbuchse	packing	PTFE	PTFE
11	Schaltwelle	stem	1.4401	SUS316
10	Kugel	ball	1.4408	CF8M
2	Teilgehäuse	body adapter	1.4408	CF8M
1	Gehäuse	body	1.4408	CF8M
Pos. item	Benennung	denomination	Werkstoff	material

1/4" - 2" 4 Schrauben/screws
2 1/2" - 4" 6 Schrauben/screws



techn. Änderungen vorbehalten / techn. changes reserved
© A+R Rev. 01 / 05.07. de-en

A+R - Armaturen® GmbH

D-32107 Bad Salzufen / Germany

Altenhagener Straße 4a • Telefon +49(0)5208-9102-0

• Telefax +49(0)5208-9102-90

A+R im Internet:

www.ar-armaturen.com

e-mail: postoffice@ar-armaturen.com