



V025 ALGAS-SDI TORREX VAPORIZER

Product Code: TX320

Product Description: Torrex™ fills the application niche where 3-phase power is available and eliminates the corrosion, evaporation and frequent 'shut-downs' associated with electric waterbaths.

Features:

- 98% thermal efficiency
- No water-glycol
- Temperature controller is simple to replace
- Heavy-duty contactor or hermetic relay
- Corrosion-free
- Liqui-SAFET™ Valve
- Thermocouple temperature sensor
- Simple and compact
- Easily fits inside cabinet
- Auto-restart after power interruption

Applications:

- Schools/ Universities
- Hospitals & Clinics
- Hotels & Resorts
- Office GenSets
- Factories

Technical Specifications:



Model	TX320	
Vaporization Type	Indirect dry electric	
Electrical Class	Hazardous Area Classification — Class I, Division 1, Group D / ATEX Zone I, EEx d IIB T3 94/9EC	
Vaporizer Approvals	FM (U.S. and Canada), NEMKO, CE, 2 PED Marked, designed per ASME	
Liquid Inlet Connection	All vaporizers have a 3/4" FNTF threaded inlet connection	
Vapor Outlet Connection	All vaporizers have a 1" FNTF threaded outlet connection	
Vaporization Capacity	Kg/h	320
	US Gal/h	160
	MMBTU/h	14.5
Design Pressure	250 PSIG 17.2 Barg	
Relief Valve Set Point	250 PSIG 17.2 Barg	
Hydrostatic Test Pressure	375 PSIG 25.9 Barg	
Shipping Weight*	180 lbs 82 kg	
Shipping Dimensions	Height	66" 1676 mm
	Width	19" 483 mm
	Length	24" 610 mm

* NF certified

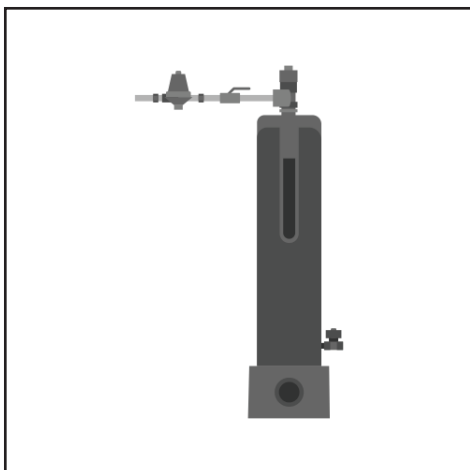

Size:

Packaging: